

A Technique for Seabed Mining

Tehnika rudarenja morskog dna

Karel Jeřábek

Institute of Technology and Business in České Budějovice, Department of Transport and Logistics, Czech Republic
e-mail: jerabek@mail.vstecb.cz

Ondrej Stopka

Institute of Technology and Business in České Budějovice, Department of Transport and Logistics, Czech Republic
e-mail: stopka@mail.vstecb.cz

Terezie Vondráčková

Institute of Technology and Business in České Budějovice, Department of Civil Engineering, Czech Republic
e-mail: terezie.vondrackova@centrum.cz

Věra Voštová

Czech Technical University in Prague
Faculty of Transportation Sciences
Czech Republic
e-mail: vera.vostova@centrum.cz

DOI 10.17818/NM.1.7.2015

UDK 551.46 : 622.24

Professional paper / *Struční článek*

Paper accepted / *Rukopis primljen: 18. 11. 2014.*

Summary

The paper deals with the necessity to look for other potential uses of unconventional sources of raw materials to meet the growing needs of human society. The first part of the paper contains the overview of the materials located in seas and oceans. This part describes the alternatives of mining, the dredging systems for extreme depths and the functional structure of the hoisting mechanism for dredging as well. The second part of the paper describes the future prospects for the extraction of minerals from seas and oceans.

KEY WORDS

dredging systems
extraction
raw materials
sea minerals
unconventional sources

Sažetak

Članak govori o potrebi da se razmotre druge potencijalne uporabe nekonvencionalnih izvora sirovina da bi se udovoljilo rastućim potrebama humanog društva. Prvi dio članka sadržava pregled materijala koji su locirani u morima i oceanima. Ovaj dio opisuje alternative rudarenja, sustave jaružanja ekstremnih dubina kao i funkcionalnu strukturu mehanizma za podizanje. Drugi dio članka opisuje buduće prospekte za vađenje minerala iz mora i oceana.

KLJUČNE RIJEČI

sustav jaružanja
ekstrakcija
sirovi materijali
morski minerali
nekonvencionalni izvori

INTRODUCTION / *Uvod*

There has been an extensive discussion within the professional and general public focused on co-existence of human society and the use of natural resources in recent decades. The basic strategy for the development of human society is shaped by the following [1], [2]:

- the rapid and uneven growth of the population
- the dependence of the human race on the raw materials and water resources
- the importance of energy resources
- the extremely uneven spatial distribution of material resources, which leads to the countries' dependence upon the raw-material trade
- the constantly evolving technological development, which is directly associated with the care for the environment
- significant changes in the spectrum of necessary material resources as a consequence of technology development

- a significant increase in the recycling and waste-free technologies.

Therefore, it is necessary to look for other potential uses of those so-called unconventional sources of raw materials to meet the growing needs of human society. This includes, for example, obtaining certain raw materials from sea water; from seabed; from salt lakes and hydro-therms, i.e. natural mineralized aqueous solutions, of which hydrothermal ore deposits are formed in the earth's crust; from gas, i.e. from the air; from underground hydrocarbon resources or helium; from volcanic emissions; from rocks; from organisms; or from the nearby universe in the future [1], [2], [3].

SEA MINERALS / *Morski minerali*

Considerable attention has been devoted to seabed research and the possibilities of its mineral wealth utilization since the end of the 19th century. The classification of minerals in seas and oceans is shown in Fig. 1 [3-5].

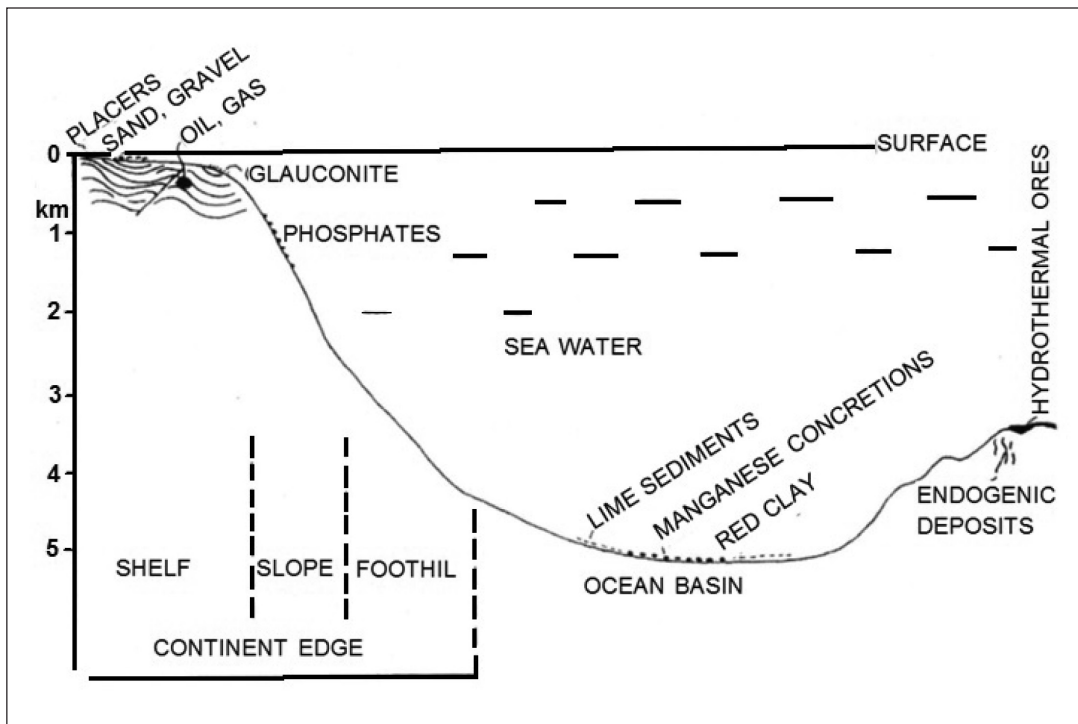

Source: [3], [4]

Figure 1 Classification of minerals in seas and oceans
Slika 1. Klasifikacija minerala u morima i oceanima

The Classification of the Materials Located in the Seas and Oceans – figure. 1 [3-6]

- Shallow-sea based raw materials: gravel, sand, calcareous raw materials, sand containing diamonds, gold and platinum, salts formed by evaporation
- Borderland raw materials: barite, phosphates, glauconite
- Deep-sea raw materials: manganese concretions, hydrothermal ores
- Raw materials from the seabed bedrock: oil, natural gas, sulphur, nickel ore, etc.
- Sea water: table salt, desalinated sea water.

Some of the raw materials have already been used for years, in particular those which are located in the shallow seas. Nevertheless, in terms of the content of scarce materials, deep seas, where lately discussed manganese concretions occur, are more interesting [3], [6].

MANGANESE CONCRETIONS / Kruti mangan

The first manganese concretions, in the shape of a black formless potato in addition to other deposits, were already mined and grabbed from the English scientific ship Challenger in 1873. It was discovered that they contained mainly manganese and iron, but their further use began to be considered in the 1930s. These concretions were seen as a new kind of promising ore after World War II, since, apart from manganese and iron, other metals were proved to be parts of them, e.g. copper, nickel, cobalt and zinc [3-6].

There are the following periods in the research of manganese concretions [3-6]:

- Cognitive in the years from 1965-1975: costly and time consuming research in order to determine the conditions of world reserves of the concretions

- Research and documentation in the years from 1975-2011: the search and exploration of manganese concretions deposits
- Mining: the United Nations announced that the licenses to mining companies will begin to be issued from 2016; (the meeting of the International Seabed Authority in Kingston, Jamaica in 2011, decided to grant permission to states, as well as to private companies).

The former Czechoslovakia joined in the common research of the seabed already in 1972 and it gained the right to explore an area of 75,000 km² in the Pacific Ocean between Mexico and Hawaii. The former Czechoslovakia (nowadays separated Czech and Slovak Republic) becomes a member of the IOM international organization (Interoceanmetal), which was established in 1987. Today, apart from the Czech Republic, the members of the IOM also include Poland, Russian Federation, Bulgaria, and Cuba [4], [6].

THE ALTERNATIVES OF MINING / Alternativne rudarstvu

The way of collecting manganese concretions from seabed is dependent on the quantity of the samples. We can distinguish the [3-6]:

- sampling of small samples
- sampling of bulk samples
- model tests of industrial mining
- industrial mining.

Sampling of small samples is usually carried out by means of the fastened or free probes working similarly as grabs etc. They allow the researchers to gain up to several kilograms of concretions.

The bulk samples of manganese concretions are obtained

mainly by so-called dredging, i.e. the scooping of concretions into the net of the dredge that is dragged along the seabed using a rope launched from a vessel. This method makes it possible to obtain a few m³ of samples weighing several tons.

During industrial mining model testing in 1978 at continual sampling of water mixtures, the flow rates of (30 ÷ 40) t/hour were achieved and ca. 600 t of manganese concretions were mined [3].

According to the experts, industrial mining would have to work with flow rates that are much higher and achieve 4 - 4.5 million tons of concretions per year to be economically advantageous. The devices for industrial mining should therefore mine 300 - 360 tons of concretions per hour [3], [4].

THE DREDGING SYSTEMS FOR EXTREME DEPTHS / Sustavi jaružanja za ekstremne dubine

The scooping of manganese concretions from the seabed by dredging is schematically shown in figure 2. The figure indicates the [7], [8]:

- 1 - vessel
- 2 - dredge
- 3 - tow rope
- 4 - hoisting mechanism consisting of a boom, double drum winch and a drum for storing the tow rope

Given that the manganese concretions occur in the depths of (4.5 ÷ 6) km, it is necessary to develop hoisting mechanisms to work with extremely long tow ropes in extreme conditions [7], [8].

The knowledge of the force ratio in the tow rope for designing and figuring out the dimension of the hoisting

mechanism is necessary. Taking into account all external influences and dynamic effects, the force ratio analysis a complex issue. Regarding the static approach sufficient for an indicative assessment of the force ratio, the load can be characterized as follows [7], [8]:

A component of the F1 force caused by the mass of the working device and its contents mass minus the buoyancy effects, see this equation (1)

A component of the F2 force corresponding with working resistors, which are determined by different theories

A component of the F3 force caused by the weight of the rope, see this equation (2)

A component of the F4 force caused by the resistance of the rope against the seawater movement.

The first two components are invariant with the depth, the F3 component increases with the mining depth.

$$F1 = (md + mk) * g - (Vd + Vk) * \rho1 * g \quad (1)$$

$$F3 = (q1 - S1 * \rho v) * g * y \quad (2)$$

$$F = F1 + F2 + F3 + F4 \quad (3)$$

The symbols stand for:

- md - the mass of the dredge [kg]
- mk - the mass of the concretions in the dredge [kg]
- g - the acceleration of gravity [m/s²]
- Vd - the volume of dredge [m³]
- Vk - the volume of the concretions [m³]
- ρ1 - the density of the tow rope [kg/m³]
- q1 - the length density of the tow rope [kg/m]
- S1 - the cross-section of the tow rope [m²]
- ρv - the water density [kg/m³]
- y - the mining depth [m]

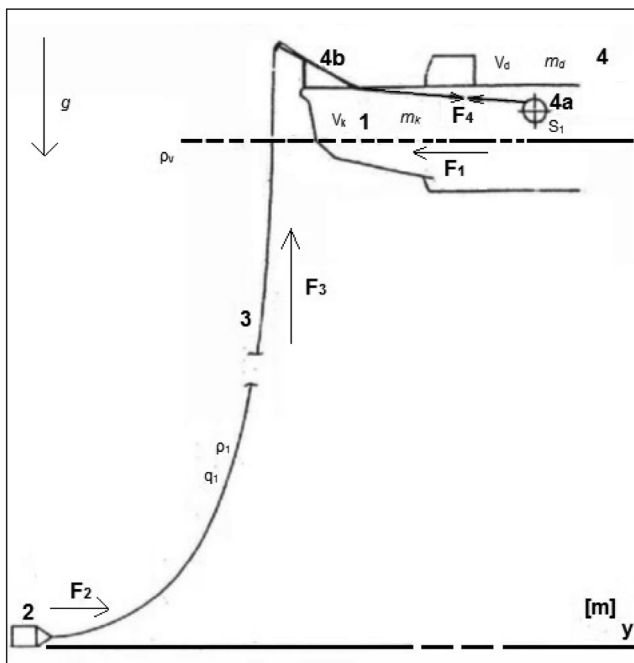

Source: [7]

Figure 2 Manganese concretion dredging principle
1 - vessel, 2 - dredge, 3 - tow rope, 4 - dredger device, 4b - boom, 4a - winch, F - tow rope force, y - mining depth

Slika 2 Princip jaružanja krutog mangana
brod, 2- jaružalo, 3-uže za tegljenje, 4-naprava za jaružanje, 4b-
bum, 4a-vitlo

THE FUNCTIONAL STRUCTURE OF THE HOISTING MECHANISM FOR DREDGING / Funkcionalna struktura mehanizma za podizanje kod jaružanja

We will not demonstrate the analysis of the functional structure to the level of the constituent and elementary functions according to the principles of construction methodology. The mere analysis of the overall functions allows us to form a morphological matrix of the alternative solutions of construction.

We can restrict the solution to two variants characterized by the following features [7], [8]:

Variant A: a steel rope, forced winding of the rope on the drum, electric propulsion - figure 3.

Variant B: a polypropylene rope, the transfer of the tow force from the drums to the tow rope by friction, the hydrostatic propulsion. Up to an 8,000-meter-long winch-towed rope is placed from the winch on a separate storage drum. The winch consists of two parallel identical units arranged one above the other. A pair of hydro motors of each of the aggregates propels the drum through the front and the planetary gearbox. The polypropylene rope is coiled several times around the pair of drums in order to reach the necessary values of the angle of the wrap, so that a reliable transfer of the propelling force is secured, even at a minimal friction coefficient between the drums and the polypropylene rope when it is wet [7], [8].

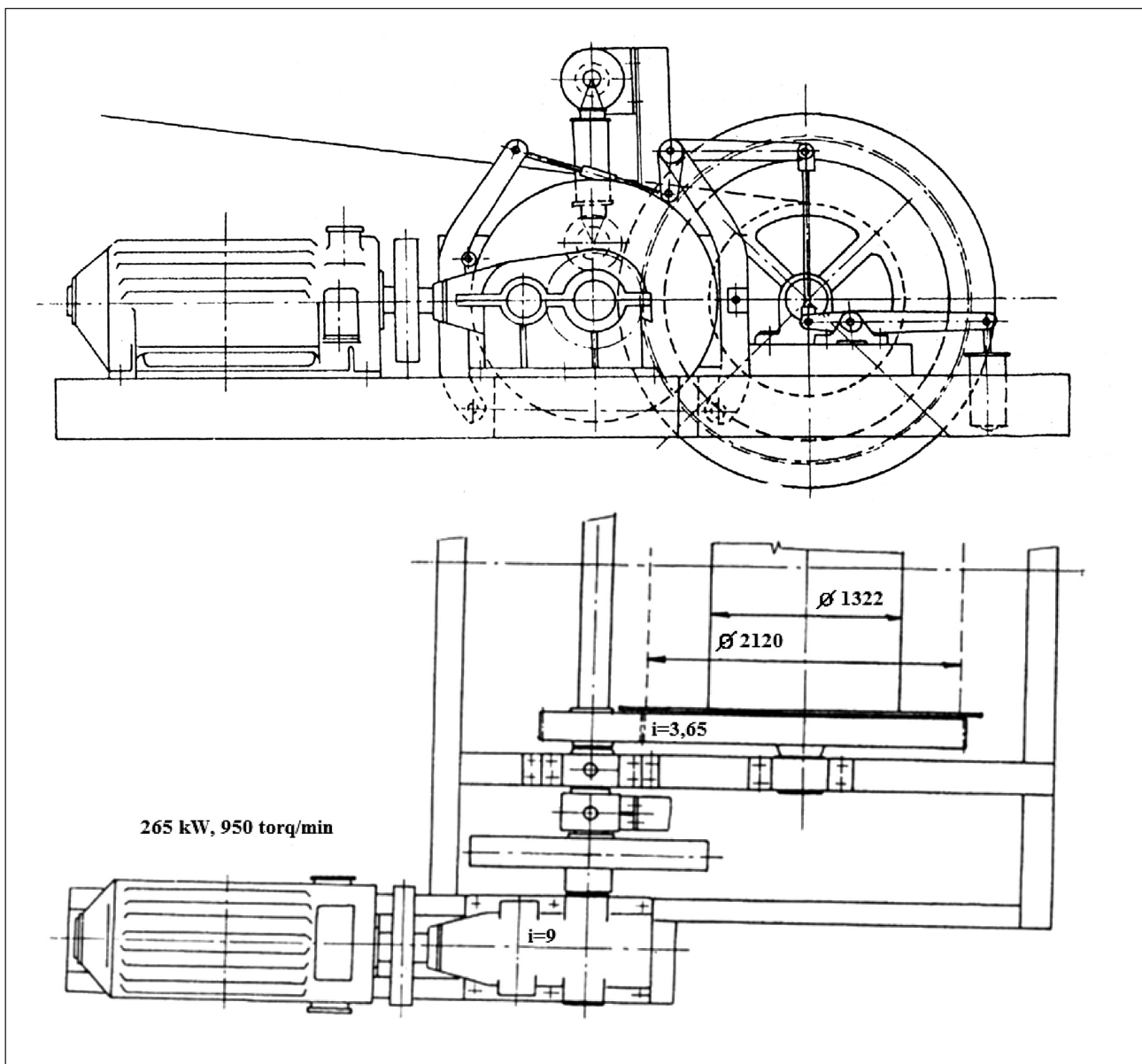

Source: [7]

Figure 3 Hoisting winch with electric drive for steely tow rope
 Slika 3. Vitlo za podizanje s električnim pogonom za čelično uže za tegljenje

THE PROSPECTS FOR THE EXTRACTION OF MINERALS FROM THE SEAS AND OCEANS / *Budućnost vađenja minerala iz mora i oceana*

The process of mineral extraction from the seas and oceans is likely to be necessary sooner or later. The business success of the potential mining companies will of course depend on mastering not only the mining process, but also the entire value chain beginning at the sampling site on the ocean floor, lifting the minerals to the surface, storing them in a transport vessel, transporting them to land, unloading and storing the minerals, their transfer to the land transport, the transportation to the place of processing into the manufacturing complex and the efficiency of the subsequent manufacturing processes. Due to the large number of segments in process chains and the even greater number of interfaces between the segments, which are the conflicting parts of the chains, the demands place upon the logistics are enormously increasing which of course increases

the costs of extraction.

The success of the mining companies in the market is guaranteed due to the demand, although the amount of profit can be debatable. Even in this, the entrepreneur entities can be promising if they manage to find those suitable progressive technologies of mining and to build the efficient logistic concepts of companies. Both technologies and logistics have a dominant element: machinery. The hourly outputs of the mining systems place high demands on the technical elements in terms of the implementation of the structural, shape and space-time transformation of matters, energies and information. From the findings of the authors described in these studies [9] and [10], the installed outputs of the propulsions from thousands to tens of thousands of kilowatts can be expected, as well as the necessity of using new propulsion conceptions without mechanical conversions, according to [11].

As far as the increase in the involvement of informatics

is concerned, it will be necessary to widen the practical applications of the simulation based on the libraries and the modelling methods, making the modelling, the simulations and the analysis of the physical effects possible in the individual machines and machine systems [9-11].

REFERENCES / *Literatura*

- [1] Kampf, R., Gasparik, J., Kudlackova, N. Application of different forms of transport in relation to the process of transport user value creation. *Periodica Polytechnica Transportation Engineering* 40 (2) pp. 71 – 75. ISSN: 03037800. 2012.
- [2] Dula, J., Bruderb, R., Bucklec, P., Carayond, P., Falzone, P., Marrasf, W. S., Wilson, J. R., van der Doelenh, B., A strategy for human factors/ergonomics: developing the discipline and profession. *Ergonomics* 55 (4). pp 377-395. 2012. doi:10.1080/00140139.2012.661087.
- [3] Seibold, E., Berger, W. *The Sea Floor*. Springer Verlag, N.Y., USA. 288 p. 1982.
- [4] Morse, J., MacKenzie, F. *Geochemistry of Sedimentary Carbonates*. Elsevier, N.Y., USA. 707. p. 1990.
- [5] <<http://www.gweb.cz/geologie/mineralogie/>>
- [6] <<http://www.mingeo.wz.cz/geostezka/geoZajimavost017.htm>>
- [7] Jerabek, K., Vostova, V. Lifting devices of extreme parameters for special purposes. In: *Lifting devices in theory and practice. Proceedings of lectures of the International conference, Tatranska Lomnica, Slovak Republic*. 1983.
- [8] Jerabek, K., Vostova, V. Cable system for extreme conditions. In: *International conference LOADO 2004 Logistics and Transport*. High Tatras, Slovak Republic. ISSN 1451-107X. 2004.
- [9] Dilefeld, m. Getriebelose Antriebe für Gurtförderer mit hoher Förderleistung. In: *18. Fachtagung Schüttgutförderertechnik*. Magdeburg. pp 25-32 s. ISBN: 978-3-930385-82-9. 2013.
- [10] Arloth, J. Systemsimulation in Entwicklung und Betrieb von Anlagen der Gewinnungs, Aufbereitungs und Fördertechnik. In: *18. Fachtagung Schüttgutförderertechnik*. Magdeburg. pp 69-83. ISBN: 978-3-930385-82-9. 2013.
- [11] Petermann, L., J., Urgen, M., Trends und Entwicklungen in der Fördertechnik. In: *18. Fachtagung Schüttgutförderertechnik*. Magdeburg. pp 5-22. ISBN: 978-3-930385-82-9. 2013.